

M.A.J Le : 24/10/2023
Indice de modif : Ind B
Nom dessinateur : JR









**NISSAN JUKE 2021
THERMIQUE et HYBRIDE
Et JUKE HYBRIDE 2023
GRILLE ARRET DE CHARGE
NOTICE DE MONTAGE**



COMPOSITION DU COLIS

REF	DESIGNATION	QTE
AS3544	ASSEMBLAGE GRILLE ARRET DE CHARGES	1
F3568	PATTE DE FIXATION GRILLE	2
S3570	SACHET DE VISSERIES	1

Composition du sachet de visserie

REF ARTICLE	DESIGNATION	QTE	PHOTO
PLOVH625	VIS HEXAGONALE M6 x 25	2	
PLOMU6	RONDELLE STANDARD Ø6	8	
FOR 0736	ECROU TENSILOCK M6	4	
D 20	ATTACHE POINGNEE	2	
PLOVH616	VIS HEXAGONALE M6 x 16	2	
PLOVH630	VIS HEXAGONALE M6 x 30	2	
PLOEDC6	ECROU NYLSTOP Ø6	2	

**PATTE FIXATION
GRILLE
F3568**

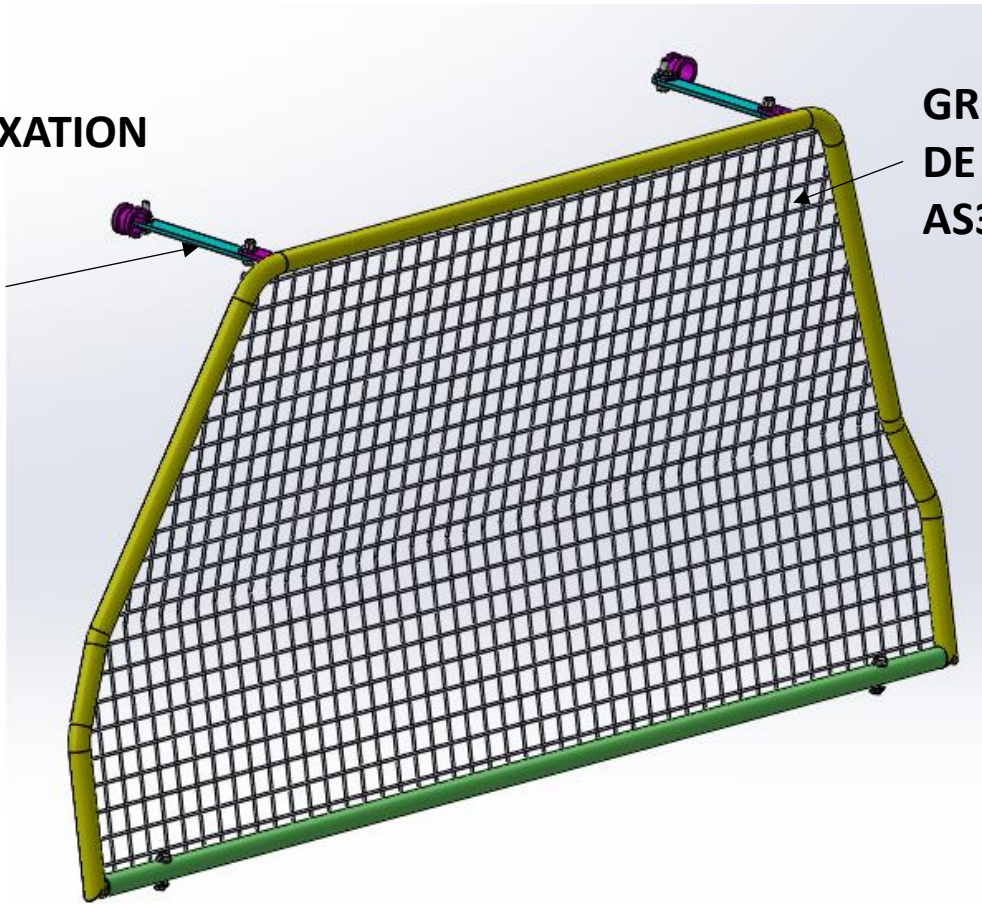

**GRILLE ARRET
DE CHARGES
AS3544**

- 1) Réceptionner le véhicule et vérifier le N° de série.**
Placer le véhicule sur une aire de travail propre et stable

- 2) Contrôler le kit**

- 3) Lire la notice de montage**

4) Fixer la grille sur l'arrêt de charges à l'aide de 2 vis hexagonale avec 2 rondelles et 2 écrous tensilock

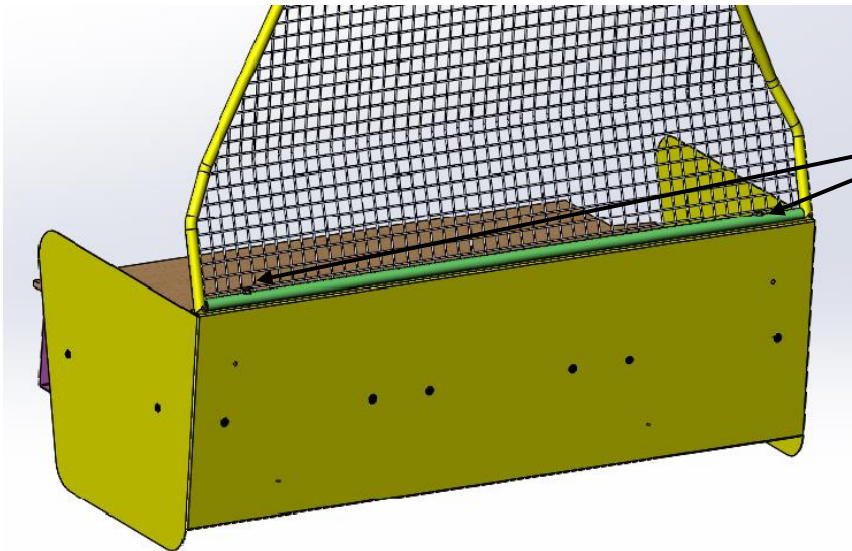

REF PLOVH630
Qté : 2



REF PLOMU6
Qté : 2



REF FOR 0736
Qté : 2

5) Fixer les pattes de fixation grille F3568 sur la grille et sur Les poignées existant

Fixer la grille et la patte de fixation à l'aide de 1 vis hexagonale M6X16 avec 2 rondelles puis 1 écrou NYLSTOP

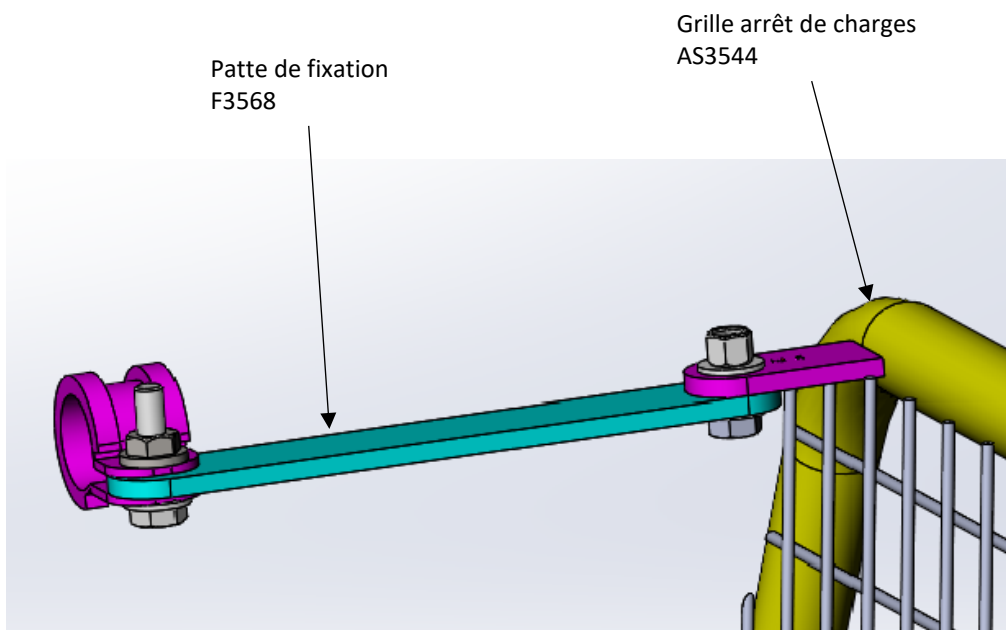

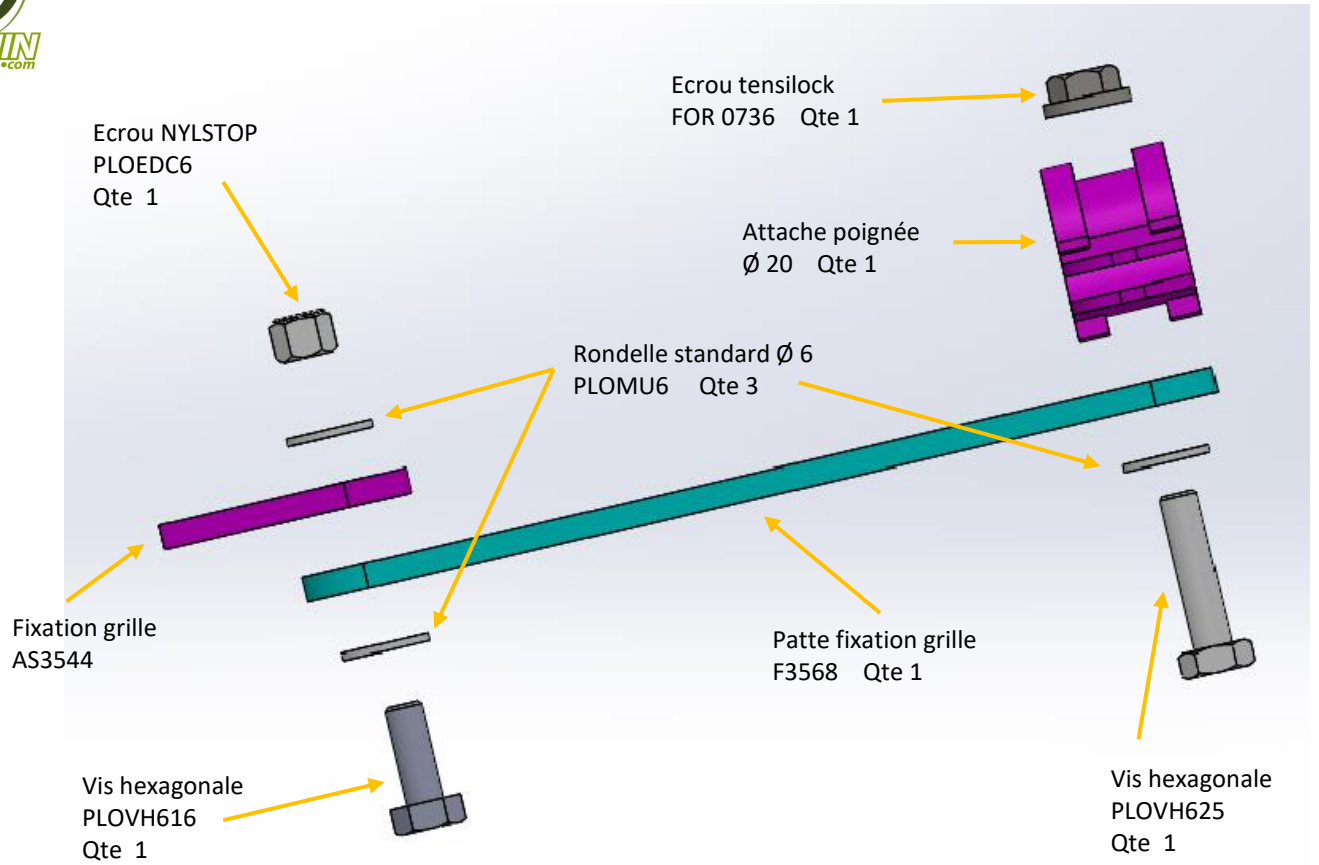

Fixer la poignée et la patte de fixation à l'aide de l'attache poignée.

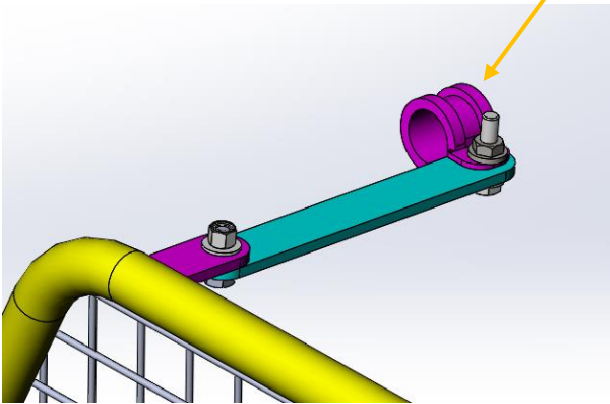

6) Nettoyer le véhicule